Signage and Display Guidelines



L A K E W A L K
A T L A S

Table of Contents

Introduction / 3

Section 1. Approvals / Design Submission Process / 4

Section 2. Signage / 6

Signage Introduction / 6

Sign Specifications / 8

Primary Signage 9

Primary Signage Lighting Methods / 12

Secondary Signage / 25

Section 3. Window Graphics / 28

Window Graphics Specifications / 28

Operational Signs /31

Section 4. Storefront Enhancement /32

Temporary Window Display /32

Awnings / 33

Outdoor Display / 34

A-Frame Stands / 35

Outdoor Furniture / 36

Introduction

Lake Walk

Lake Walk is the premier lifestyle center of Atlas and the Bryan/College Station community, offering a holistic approach to living well - featuring retail, dining, entertainment, and hospitality. Lake Walk will offer a curated combination of lifestyle amenities for those looking to live well in a new and thriving community.

Welcome

The purpose of this document is to help Lake Walk businesses be successful through the use of thoughtful signage and display guidelines. These guidelines will assist in the visioning process and provide guidance for the selection of elements for general appearance, signage, display materials, and furniture.

The overall vision for the Lake Walk retail environment is one of pedestrian friendliness, creativity, modern simplicity and comfort. All businesses are encouraged to express their brand presence in an outward display of quality and uniqueness contributing to this special, energizing place. The expectation at Lake Walk is for tenants to develop a strong visual character for the interior and exterior of their space. By engaging in good design practices and integrating brand expression into the overall tenant presentation we can ensure that Lake Walk will be an engaging place that will leave a lasting impression for our visitors.

At Lake Walk, businesses will need to be in compliance with the requirements of this guideline document, the BioCorridor Planned Development District Ordinance, the American's with Disability Act (ADA), Texas Accessibility Standards (TAS), as well as any other applicable building codes and ordinances.

Section 1 of this document provides information about the process for business owners to assist them in the creation of submission of signage and display designs to the Landlord.

Section 2 provides background on signage including specifications, sign types, definition of primary signage, lighting and secondary signage. Included in this section are examples well designed, acceptable sign types.

Section 3 provides description and examples of support graphics including window graphics and operational signage.

Section 4 identifies ways for a business to enhance the exterior of their space with window displays, awnings, outdoor display, A-frame stands, outdoor furnishings.

Section 1. Approvals / Design Submission Process

Tips and Recommendations

Property approval entity name Atlas | Lake Walk will also be known as Landlord. Potential tenant will also be known as Tenant.

Potential tenants are encouraged to seek out design professionals to help prepare designs and submission materials.

Architects and experiential graphics design firms can assist in developing a cohesive design vocabulary for your tenant space.

Signage and other design elements should be considered part of the overall design presentation, and should complement the architecture of the proposed space.

The tenant presentation should work with surroundings to create a sense of place not only for an individual business and its neighbors, but for the development as a whole.

All signage and display items must be approved by a Lake Walk Review Board (LWRB) before submitting to the necessary governmental approval entities for permitting. This is a two step process:

Step One / A.1: Conceptual Design Submission

Step Two / A.2: Formal Design Submission

Step One

A.1. Conceptual Design Submission

The purpose of this submission is for the applicant business to describe to the Landlord the following: overall exterior design vision for the tenant space, proposed architectural modifications, signage and graphics, and display items and furniture. The Landlord will want to understand what the business is proposing from a holistic perspective. Though not required, informal meetings with the Landlord and leasing representatives are encouraged to get early feedback before time and expenses are unnecessarily expended.

Conceptual Design Submission Requirements

Two printed copies of the following material along with digital files in PDF format are required:

- a. Plan showing proposed demising space and address;
- b. Tenant description and contact information;
- c. Exterior elevations, sketches, renderings or measured drawings depicting the overall architectural and signage characteristics;
- d. Colors, materiality, illumination types, and size of intended architectural features and signage;
- e. Drawing or precedent imagery (reference images) that supports the intended vision for the business facade and display elements;

A.1 Conceptual Design Submission Process

- a. Concepts must be approved by the business's franchiser, licensor or parent company before submitting to the Landlord;
- b. The Landlord will respond in writing within fifteen business days of receiving a complete submission package. Comments may provide directly or on the complete concept submission material;
- c. If the Landlord has not responded to a concept submission in fifteen business days, then the submission is to be deemed rejected;
- d. Once the Landlord has rejected a submittal or requested changes, a new submittal will be required from tenant applicant;
- e. The Landlord will notify the tenant of approval of the conceptual submission. This begins the formal design submission process;

Section 1. Approvals / Design Submission Process, continued

Tips and Recommendations

Base architectural drawings of existing storefront or elements such as canopies and facade/wall details may be obtained from landlord.

Tenants shall provide working drawings to the Landlord and any current building landlord.

No construction shall commence until written approval from the Landlord has been obtained.

The business shall provide to the Landlord and any current building landlord, copies of all permits and approvals.

Step Two**A.2 Formal Design Submission**

Following approval of Step One, the business applicant will submit the formal design submission to the Landlord. Concepts approved in Step One (Concept Design Submission) may now be developed into implementation documents. (Through any required design professionals).

The required design professionals include any professional design services such as architects and engineers for building envelope development. The tenant may also consider (though not required) environmental graphic designers to provide designs and fabrication documents for signage. Signage fabricators typically provide the necessary engineering requirements for signage installation.

Formal Design Submission Requirements

Two printed copies of the following material along with digital files in PDF format are required:

- a. Detailed construction documents showing detailed information on materials, colors, dimensions, design details, connection details, lighting features for architectural features, and signage/graphic elements (see Signage Overview for Signage requirements);
- b. Exterior color elevations or renderings depicting the overall architectural and signage characteristics;
- c. Specifications and quantities for supporting elements such as furniture, plant pots and display elements;

A.2 Formal Design Submission Process

- a. Business applicant must have approval from tenant's franchiser, licensor, or parent company, of the concepts before submitting to the Landlord;
- b. The Landlord will respond in writing within fifteen business days of receiving a complete submission package. Comments may be made directly on the complete concept submission material;
- c. If the Landlord has not responded to a concept submission in fifteen business days then the submission is to be deemed rejected;
- d. Once the Landlord has rejected a submittal or requested changes a new submittal is required from business;
- e. The Landlord will notify the tenant if approved. The tenant is responsible for all Landlord approvals and building permits;
- f. The tenant will notify the Landlord prior to beginning work and will provide construction schedule along with copies of all permits and approval documents;
- g. The Landlord will provide written notification to proceed to the tenant;

Section 2. Signage

Introduction

The following sections are guidelines for signage and storefront enhancements that the Tenant will propose in their design submittals.

All signage should be designed as a part of the overall Tenant presentation. Signage should complement the Tenant storefront as well as the architecture of the building. Tenant presentation should work with surroundings to create a sense of place for the individual tenant and its neighbors, and also for the development as a whole.

Nothing in this document shall be construed to preempt any local, state, or federal regulation or ordinance. It is the responsibility of each Tenant to ensure that proposed signage meets all requirements of the local city sign regulations as well as all applicable building or other governmental or regulatory requirements. Any deviation from these criteria must be approved in writing by the Landlord and any current building landlord.

The approval by the Landlord of any sign plan submitted to the Landlord shall not constitute the assumption of any liability on the part of the Landlord for the plan's accuracy or conformity with any building code, signage code or other governmental and regulatory requirements. The Tenant shall be solely responsible for the accuracy and conformity of the plans and responsible for obtaining all permits and approvals from all appropriate governmental and regulatory bodies.

Tenants are encouraged to use professional environmental graphic designers and signage companies to determine sign design and specifications. All businesses are required to have a unique identity. If a Tenant does not have an identity, the Landlord will refer the business to a preferred professional designer to establish an identity. Generic business names such as "Cleaners," "Bank," "Diner," etc. are not allowed.

Signs may use the Tenant's standard corporate identity letter style, subject to the Landlord approval. In the event that the Tenant's standard letter style is unacceptable or non-existent, the Tenant shall be required to use a typeface supplied by the Landlord or any current building landlord.

Section 2. Signage / Sign Specifications

Signage Overview

Signage submittals are to include all elements of the storefront presentation as described in the following criteria:

1. Electrified signs must carry an Underwriter's Laboratory (UL) tag. Signs of the flashing, rotating, moving, blinking, or animated type are not permitted.
2. The design, including sign illumination and location of all signs, must be approved in writing by the Landlord and shall be subject to the Landlord's sole discretion as to design, size, and location. See Tenant Presentation Section A; the working drawings must indicate all of the following:
 - a. Lake Walk name;
 - b. The Tenant name;
 - c. The space number;
 - d. The complete address;
 - e. The type and size of all lettering;
 - f. Elevation view of storefront showing sign (drawn to scale) with overall height and width dimensions of sign; overall square footage of sign; detail dimensions of major sign elements graphics, letter forms, etc.); and the linear dimension of the allowable areas of design presentation;
 - g. A technical section (to scale) through the sign and storefront showing all pertinent construction details. Describe all fastener and weld details. Show attachment detail to building;
 - h. Colors and finishes of all materials;
 - i. Wattage and light intensity by lamping type;
 - j. Location of penetrations for conduit and sleeves, etc. required for sign installation;
 - k. A photograph of the storefront with sign location indicated;
3. All drawings should show actual construction of the sign. No standard details will be acceptable. Base architectural drawings of storefront and elements such as canopy and facade/wall details can be obtained from either the Landlord.
4. The Tenant shall submit conceptual designs and sign working drawings to the Landlord. No sign shall be installed until the Landlord's written approval has been obtained. The Tenant shall provide the Landlord a copy of the signage permit prior to sign installation.
5. In the event that sign(s) do not conform to the Landlord's criteria or otherwise do not receive written approval within 15 business days, it is deemed rejected. The Tenant shall re-design the sign in question, at the Tenant's expense.
6. Signs are to be painted colors that reinforce the Tenant's identity or that are in the development's standard colors. Red, green, or yellow as a primary or majority color of Tenant signage is prohibited without prior Landlord approval. This includes material finish as well as illumination.
7. Tenant space/suite number are to be designed as part of overall design presentation, and should be in line with specific property's sign criteria.

Section 2. Signage / Sign Specifications

1. The sign and any part or parts thereof, except as otherwise provided in these criteria, shall be located within the limits of the Tenant's storefront premises.
2. All signs must be new and custom-made. Restored vintage or re-purposed signs may be acceptable, with written approval by the Landlord.
3. The term "primary identification signage" or "facade signage" used in this document refers to the Tenant's most prominent display of identity. Primary identification signage may be placed anywhere within storefront envelope, and may be any sign type listed in this document. The term "secondary identification signage" denotes any sign that supports the aesthetic or branding message of the primary identification sign or Tenant identity. Primary signage shall be larger than any single secondary signage element. The use of primary/secondary signage is intended for the Tenant to have opportunity to convey a hierarchy of messaging. Placement locations will require the Landlord review and approval.
4. The signage contractor shall perform all cutting and patching of existing surfaces where required for installation of the signage work included herein. The procedures proposed for the accomplishment of cutting and patching work shall be submitted by the sign contractor to the landlord for approval. Submission to also include work schedule showing start of work, finish date and any other important dates within project time line. The procedures shall include a detailed description of the methods and equipment to be used for each operation. The sequence of operations of all materials for patching and repairing of existing surfaces shall match existing adjacent surfaces in all respects.
5. Service/rear egress/delivery doors to business areas will have standard identification (Tenant's name and address number) designed and installed by the landlord at the Tenant's expense. No other signing or graphic is permitted at the service entrance.
6. Illumination shall be internal to the sign or by external front lighting. Light sources shall not cause glare hazardous to pedestrians or vehicle drivers. Lighting for internally illuminated signs is to be white. With the exception of neon signs, colored lamps shall be permitted only with landlord approval.
7. Face illumination to only consist of day/night type face material so that face reads as solid element during the day and illuminates at night. Illumination to be consistent with no shows or hot spots. Standard type acrylic faced letters/signs with colored faces are prohibited or by the Landlord approval only.
8. Non-illuminated storefront facade signage requires written the Landlord approval.
9. If applicable, the business shall provide a dedicated circuit for the Tenant's signage illumination and shall coordinate and utilize Landlord-provided master switching relay system for all illuminated signage.
10. Red, green or yellow as a primary or majority color of Tenant signage is prohibited without prior Landlord approval. This includes material finish as well as illumination.
11. The Landlord is not responsible for cost incurred for replacement or construction of signs that do not conform to these sign criteria or for signage that did not receive prior Landlord approval.
12. Prohibited sign elements and materials include, but are not limited to the following:
 - a. Flashing lights
 - b. Animated components
 - c. Vinyl trim caps on letterform/sign face or return. See note J for face material limitations. Use of minimal size aluminum retainers or other low profile retainers for letterform/sign face are encouraged.
 - d. Cabinet signs with illuminated, translucent background and silhouette letters.
 - e. Vacuum-formed plastic letters.

Section 2. Signage / Sign Specifications

- f. Paper, cardboard, stickers, or decals applied to or located behind the storefront glazing.
- g. Sandblasted wood signs in natural wood finish with painted, raised letters and/or logos.
- h. Advertising placards, banners, pennants, names, insignia, trademarks, or other descriptive or promotional material not designed as part of the business's overall presentation and brand identity may not be affixed or maintained on windows, glass fixtures, equipment, or another area of the storefront without owner approval.
- i. Exposed Raceways, Exposed Ballast Boxes or Electrical Transformers. If raceway is used, it must be integrated into design of sign. Note applies to wall/facade and canopy signs.
- j. Acrylic faced letterforms and sign cabinet. Only allowed acyclic faced elements are day/night type where face appears a solid color during the day and illuminates white at night. See note C for trim cap limitations unless approved in writing by Landlord.
- k. Roof mounted signs. May be necessary depending on development specific architectural conditions. All roof mounted signs to be approved by the Landlord, and only used if allowed by local code and if there is no acceptable mounting location on storefront facade.
- l. Non-English characters, letters, or logos on primary signage.

Note: The Landlord may modify this list at any time to include any material specific to a business's signage design and/or fabrication that in the Landlord's opinion is not in keeping with the architectural character or overall quality of the development.

Section 2. Signage / Primary Signage

Primary Signage

Primary signage may be made in any number of methods, materials and can incorporate many different lighting methods. This signage serves as the main identification for the Tenant's space. Tenants are allowed one sign per facade, no more than two signs maximum unless by written permission from the Landlord.



Section 2. Signage / Primary Signage

Tips and Recommendations

Using simple shapes and color palettes help with visibility and contrast.

Dimensional pin-mounted letters add depth and interest.

Keep lettering simple and minimal.

Use colors and materials that contrast with the facade.

Illumination allows your sign to be effective at night.

Use fonts that are easy to read.

Primary Signage

Tenant shall be allowed one (1) storefront facade sign, however, a Tenant whose storefront turns a corner or has two public facing entrances may have one (1) sign on each facade for a maximum of two (2), providing the arrangement of same meets the approval of the Landlord and is within the restrictions of the local sign code.

If a Tenant elects to have a facade sign in addition to another sign type, one shall be deemed the primary identification through a hierarchy of dimensions or sizing. Use of second primary identification requires prior landlord approval.

Facade sign content shall be limited to the Tenant name. Description of services or products offered is not allowed on facade sign. Additional brand language requires prior Landlord approval. Multi-line signs require prior Landlord's approval and should be no more than 30" overall height, or the maximum allowed by the specific property. Overall signage length to be determined case by case at the discretion of the Landlord based on frontage and facade proportions.

Signs may have internal or external illumination. External illumination shall be well integrated into storefront design. A projecting facade sign, or blade sign, is an option for Tenants with corner locations and is only permitted with prior Landlord approval.

Any external light fixtures shall be Landlord's standard, Cooper Lighting Cambria 922 or PAR20 bullet sign lighter.

- a. recommend 1-LED2741 light source (this is wide angle)
- b. with OSL lens option
- c. lights mounted w/ O.C. spacing, approx. 24" (28" max.)

Tenant may specify a fixture of equal or better quality, subject to the Landlord's review and approval. External light fixtures to be white in color.

Facade signs to have a minimum clearance of 10" from upper and lower edges of sign band, and 12" clearance from demising wall center line. Facade signs and other sign elements may not be installed outside of Tenant frontage without prior Landlord approval.

Refer to local codes and ordinances for maximum sign size for business type.

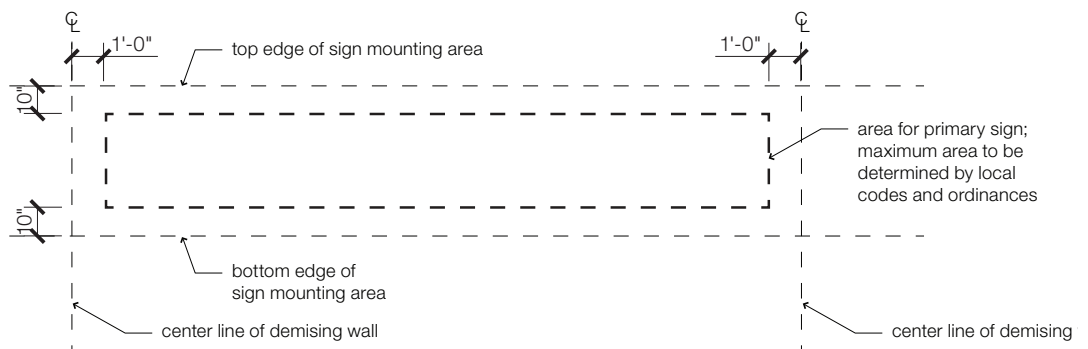

1 Elevation Diagram SCALE: 3/16"=1'

Section 2. Signage / Primary Signage

Primary Freestanding Signage

A freestanding sign is most appropriate when a freestanding business is set back from the street or sidewalk. A freestanding sign may have information on two faces and shall be appropriately scaled to compliment the identifying business.

Business shall be allowed one (1) freestanding sign, however, a business whose has frontage on two streets in which case one primary identification sign per street face allowed providing the arrangement the approval of LWRB and is within the restrictions of the local sign code.

Place freestanding signs near the public right-of-way where appropriately scaled for pedestrians or slow speed surface streets, a minimum of five feet from the street right-of-way and ten feet from all interior side lot lines. No freestanding sign should be placed in a manner that obstructs the pedestrian walkway or visibility from street intersections or parking lot entrances or exits.

If a business elects to have a freestanding sign in addition to another sign type, one shall be deemed the primary identification through a hierarchy of dimensions or sizing. Use of a second primary identification sign requires prior Landlord approval and be within the restrictions of the local sign code.

Freestanding sign content shall be limited to the business name and address. Description of services, tag lines, or products offered is not allowed on a freestanding sign. Additional brand language requires prior LWRB approval.

The size of new signs should be appropriate to the architectural context, suburban style monument signs, reader boards or changeable messaging is not permitted. Sign size should not exceed 50 square feet on either side, for a total of 100 square feet.

Appropriate size shall be determined by conditions specific to individual properties.

Limit the height of freestanding signs to no more than six feet.

Freestandings signs may carry more than one business name but must considered as part of the overall building signage plan. If more than one business is displayed they should be considered primary occupants of a building.

Refer to LWRB signage specification section for illumination and other signage information.

Any external light fixtures may be Landlord's standard, Cooper Lighting Cambria 922 or PAR20 bullet sign lighter.

- a. recommend 1-LED2741 light source (this is wide angle)
- b. with OSL lens option
- c. lights mounted w/ O.C. spacing, approx. 24" (28" max.)

Tenant may specify a fixture of equal or better quality, subject to LWRB review and approval. External light fixtures to be white in color.

Freestanding signs must have a maintained groundplain of plantings, mulch, gravel, or other improved dressing as a component of an overall landscape plan. Bollards or other traffic impediments are not permitted. Signs must not interfere with street trees or the future growth of street trees.

Section 2. Signage / Primary Signage

Primary Freestanding Signage Continued



Section 2. Signage / Primary Signage Lighting Methods

Basic Signage Illumination Characteristics



Exposed Bulb



Exposed Neon

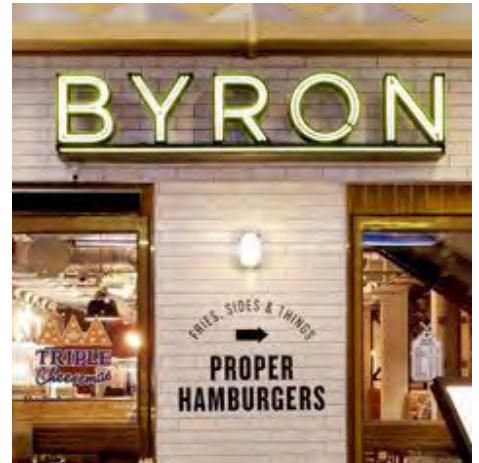

Open Channel Neon



Internal Illumination
Landlord approval only



External Illumination



Halo Illumination

Section 2. Signage / Primary Signage Lighting Methods

Option 2a / Painted lettering with gooseneck external illumination

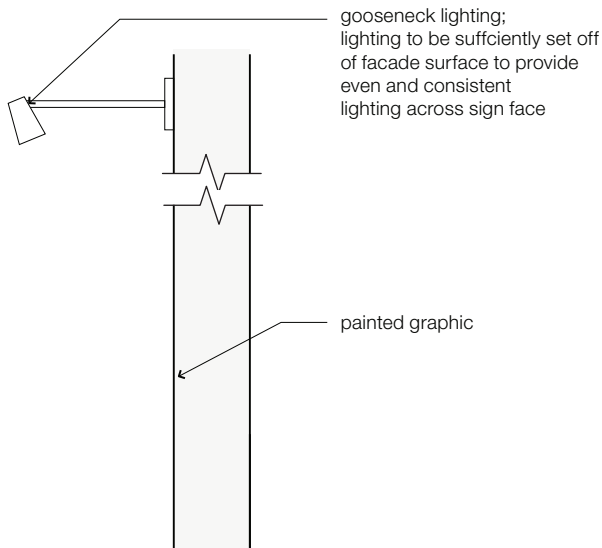

painted graphic with
external illumination (light source
may be mounted above or
below dimensional letters)

Section Detail



Front View

Section 2. Signage / Primary Signage Lighting Methods

Option 2b / Individual dimensional letterforms with gooseneck external illumination

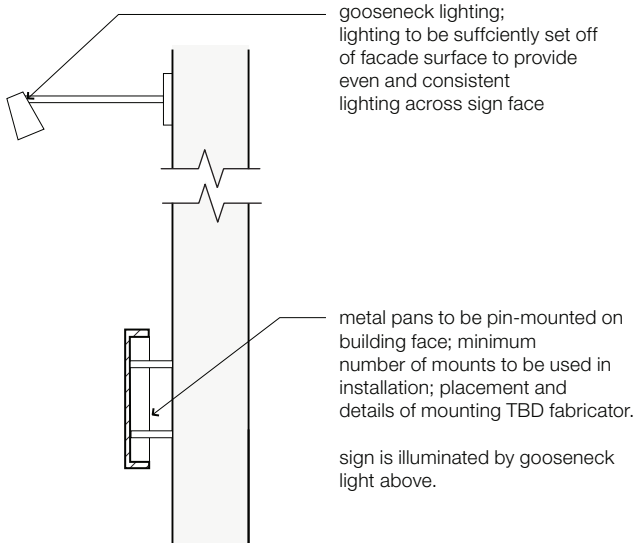

dimensional letterforms with external illumination (light source may be mounted above or below dimensional letters)

Section Detail



Front View

Section 2. Signage / Primary Signage Lighting Methods

Option 2c / Reverse channel letterforms with internal halo illumination

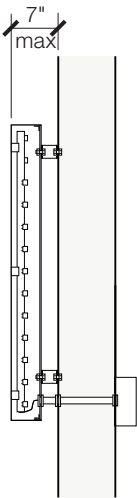

pin-mounted reverse channel-letter with halo-illumination

Section Detail



Front View

Section 2. Signage / Primary Signage Lighting Methods

Option 2d / Reverse channel letterforms with internal halo illumination on facade cabinet



Note

This option is acceptable only if facade concealed raceway is not possible.

Requires Landlord approval for classification.

Exposed raceway not permitted.

Back plate design integral to be overall design presentation.

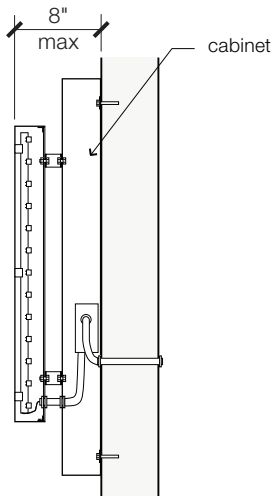

reverse channel-letter with halo illumination mounted on cabinet

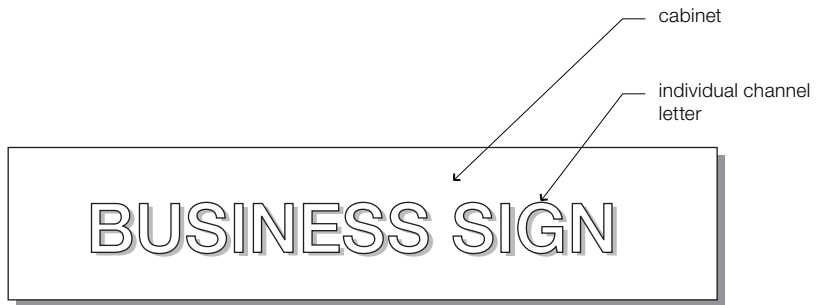

Front View

Section Detail

Section 2. Signage / Primary Signage Lighting Methods

Option 2e / Internally-illuminated dimensional push-through acrylic letters with cabinet



Note

This option is acceptable only if facade concealed raceway is not possible.

Requires Landlord approval for classification.

Exposed raceway not permitted.

Back plate design integral to be overall design presentation.

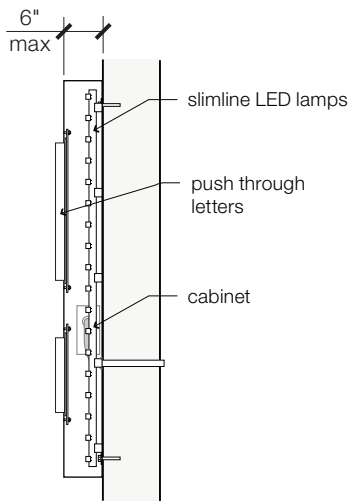

push-through letters with internal illumination

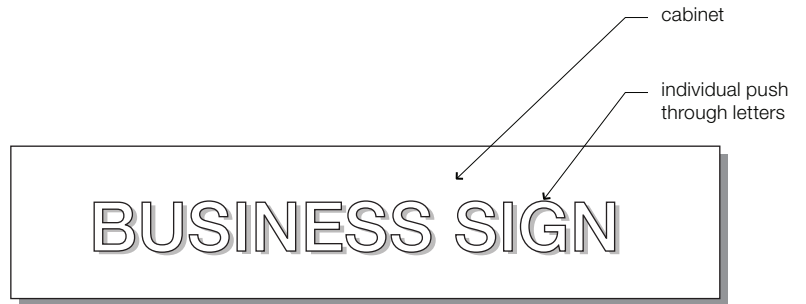

Front View

Section Detail

Section 2. Signage / Primary Signage Lighting Methods

Option 2f / Individual dimensional letterforms with exposed bulb illumination

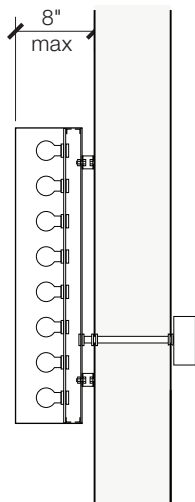

open-channel letter with bulb infill

Section Detail

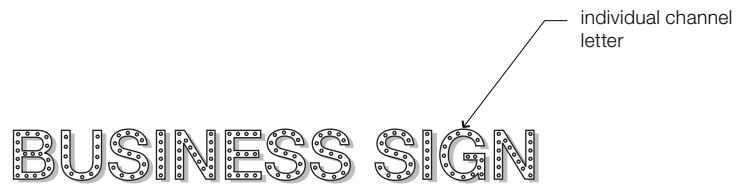

Front View

Section 2. Signage / Primary Signage Lighting Methods

Option 2g / Individual dimensional letterforms with exposed neon tube illumination

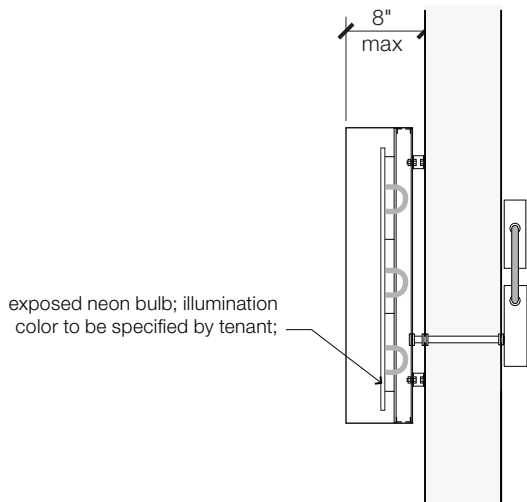

open-channel letter with neon tubing; conceal transformer and power



Front View

Section Detail

Section 2. Signage / Primary Signage Lighting Methods

Option 2h / Individual open-channel letterforms with exposed neon tube illumination



reverse channel letters
with exposed neon;
no exposed electrical; electrical
to enter through facade surface

exposed neon bulb; illumination
color to be specified by tenant;

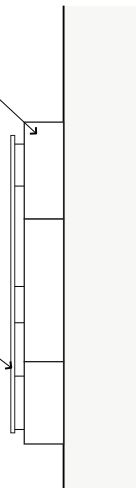

reverse-face channel letter
with surface mounted neon
lighting

Section Detail



Front View

Section 2. Signage / Primary Signage Lighting Methods

Option 2i / LED Internally face-lit channel letterform



Landlord Specs

Sign type only for anchor/junior anchor consideration and can only be implemented with Landlord approval.

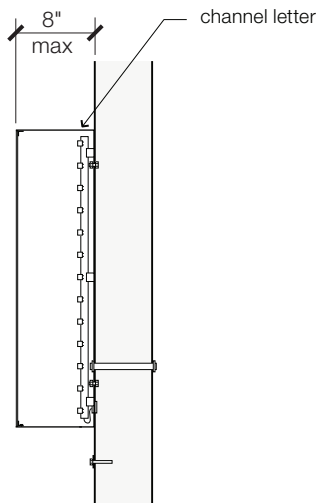

open-face channel letter with LED infill and perforated metal face. No plastic or rubber trim rings allowed.

Section Detail

BUSINESS SIGN

Front View

Section 2. Signage / Primary Signage Lighting Methods

Option 2j / Canopy Signage

Depending on the architecture of the space, applicable businesses may, with Landlord approval, use a canopy mounted sign.

Approved businesses shall be allowed one (1) canopy sign, however, a Tenant whose storefront turns a corner or has two different public facing entrances may have one (1) sign on each facade, thereof, providing the arrangement meets the approval of the Landlord and is within the restrictions of the local sign code.

Canopy sign cannot be used as primary retail identification if the business also has a facade sign.

Signs may have internal or external illumination. External illumination shall be well integrated into storefront design. All electrical conduit and raceways shall be hidden. No conduits will be exposed. Raceways shall be minimized and should not be a component of the sign presentation. LED lighting shall be provided by Tenant and will not be built into the canopy. Any modifications to the canopy will be made with prior Landlord approval, and will require Tenant to ensure that both wall and roof systems maintain structural stability and water-tightness.

Due to the varying nature of canopy conditions, the Landlord shall address each location's requirements case by case and in collaboration with the Tenant.



Section 2. Signage / Primary Signage Lighting Methods

Option 2j / Canopy Signage Diagrams

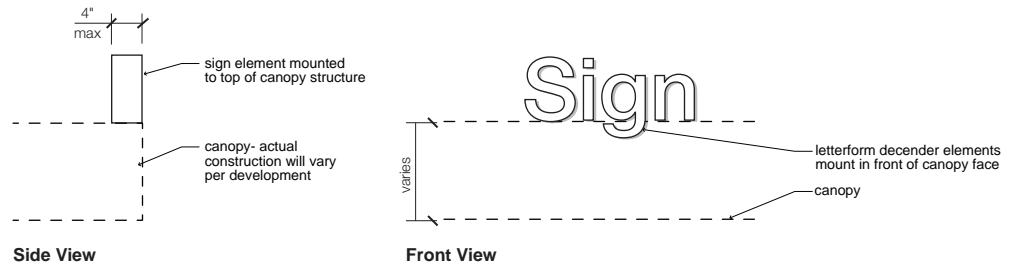

- Some tenant signs will have decenders that need to protrude in front of the canopy fascia, consider all cap font options with no decenders
- Construction of canopies vary, verify conditions
- No exposed fasteners, welds, or conduits

Canopy Sign Option 1

SCALE: NTS

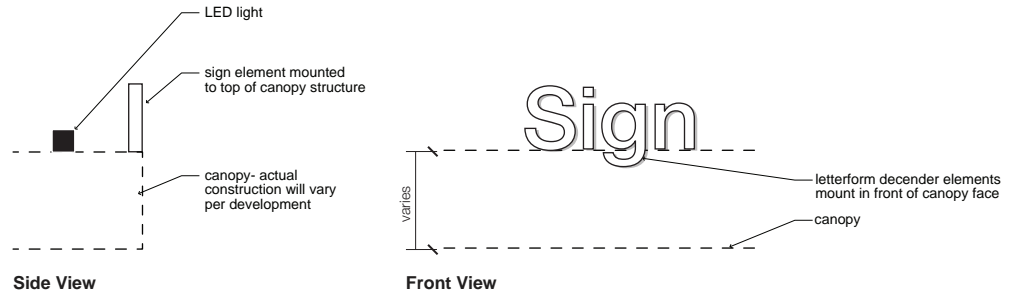

- Some tenant signs will have decenders that need to protrude in front of the canopy fascia, consider all cap font options with no decenders
- Construction of canopies vary, verify conditions
- No exposed fasteners, welds, or conduits

Canopy Sign Option 2

SCALE: NTS

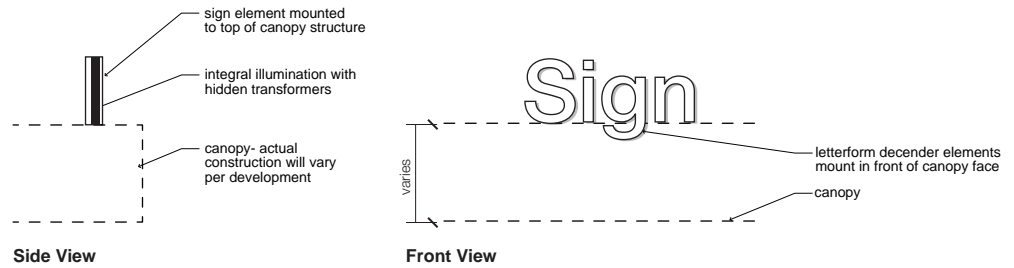

- Some tenant signs will have decenders that need to protrude in front of the canopy fascia, consider all cap font options with no decenders
- Construction of canopies vary, verify conditions
- No exposed fasteners, welds, or conduits

Canopy Sign Option 3

SCALE: NTS

Section 2. Signage / Secondary Signage

Tips and Recommendations

Secondary signage is an important element for bringing a Tenant identity down to the pedestrian level, increasing visibility but also adding to the fabric of the streetscape.

These signs are usually smaller and more pedestrian focused. The most common is a projecting or “blade” sign mounted overhead perpendicular to the business space but these can take many forms and should be seen as “jewelry” – elements bringing richness and personality to the environment.



Specifications

Where applicable, every business shall be allowed one (1) secondary sign, however, a Tenant whose storefront turns a corner or may have two public facing entrances may have one (1) secondary sign on each facade with a maximum of two, providing the arrangement of same, meets the approval of the Landlord, and is within the restrictions of the local sign code. Secondary signs will be located within the Tenant's storefront area.

Secondary signage may include the individual logo and typography of the retail enterprise. All secondary signs may have dimensional qualities (such as dimensional letterforms and graphics, frame elements, etc.) and integral illumination. Maximum size shown on the adjacent diagrams or Landlord approved dimension.

Secondary signage may not obstruct any pedestrian way. Clearance below sign shall comply with restrictions of all applicable codes and ordinances. A minimum clearance of 9'-0" is required on upper facade, or clearance as determined by local code. Secondary signs under the arcade sections will have to be wall mounted and parallel with the storefront.

Suspended signs are preferred. If canopy is not present, is not of sufficient size to support suspended sign, or has a low clearance, a projecting blade is allowed with Landlord approval. It is the Tenant's responsibility to meet local requirements when applying for permit.

Brackets and other mounting devices shall be considered as part of the overall design.

Section 2. Signage / Secondary Signage

Blade Signs Mounting Diagrams

Shown in black and white for clarity.

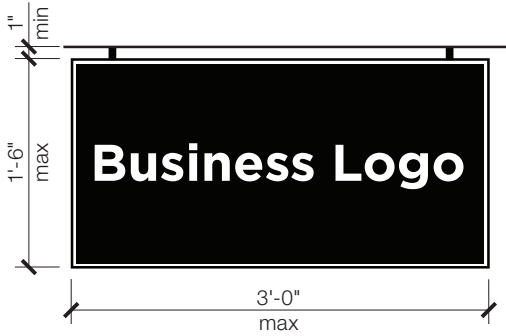

1 Elevation
SCALE: 3/4"=1'

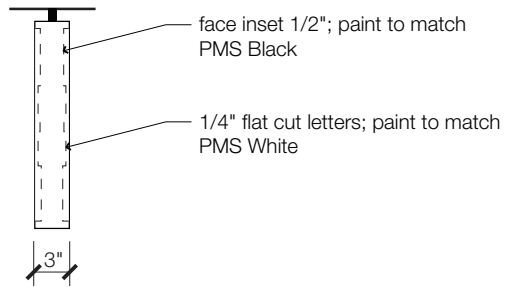

3 End View
SCALE: 3/4"=1'

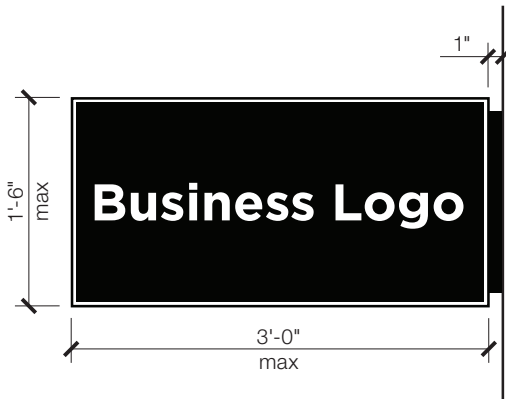

2 Alternate Elevation
SCALE: 3/4"=1'

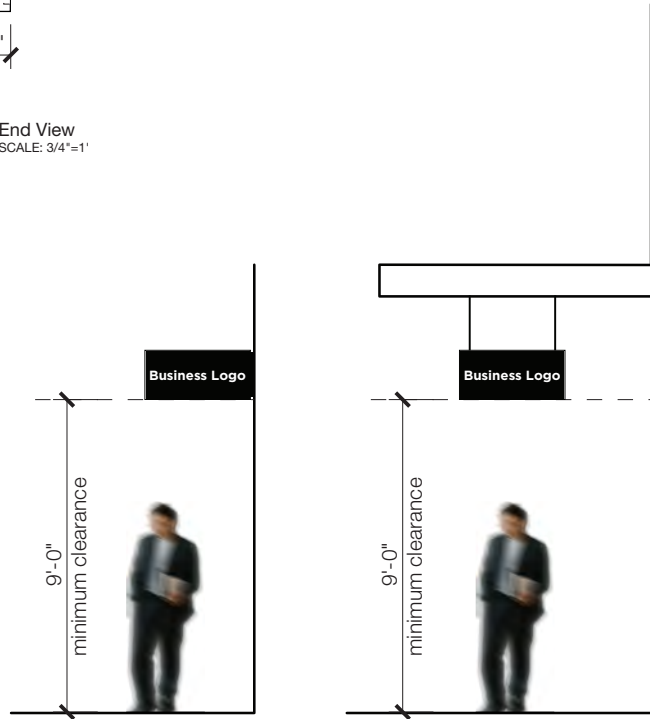

4 Mounting Elevation Diagrams
SCALE: 3/16"=1'

Section 2. Signage / Secondary Signage

Alternate Secondary Sign Configurations

Whenever possible, tenants are encouraged to be expressive with their signage.



Section 3. Window Graphics

Tips and Recommendations

Storefront graphics should be crafted and unique.

Simplicity is key for legibility.

Should be consistent with brand and logo.

Window Graphics Specifications

Elements such as tertiary identification features, custom hours of operation and open/closed signs add visual detail and interest to a business's overall presentation. In urban environments the pedestrians do not experience the business facade from far distances but very close and at eye level. It is important that any supporting elements help promote the brand identity of a business but also reinforce a sense of craft and quality about the development. Supporting graphics are best executed by utilizing the business's windows. Aside from facade enhancements that are typically permanent, items placed on the facade windows can be semi-permanent as they should be made of materials that are long lasting and durable but allows for changeability.

This section is specific to permanent or semi-permanent identification or operational graphics and not temporary advertising or display elements. (See Section 4 for temporary graphics.) attached to the facade glazing. Window graphics includes any permanent or semi-permanent material attached to the storefront glazing for Tenant identification. Landlord design approval must always be obtained prior to moving forward with permitting and fabrication.

Handwritten signs, illuminated signs, over sized banners, credit card or organization stickers are not permitted.

With prior Landlord approval, small-scale graphic elements may be placed on the business windows at the pedestrian level. These graphic elements may include Tenant logo, name, website, other social media addresses, store hours and address.

Public information decals, subject to Landlord approval, may be used as required by applicable codes or government regulations.

Signage applied to storefront windows may occupy no more than a total of 25% of overall glazed storefront area. This allowed area may be divided up among multiple signs and placements, provided the aggregate total area is within the 25% limit. Size of individual window signs to be appropriate scale based on messaging, placement and position within the hierarchal system of business signage and storefront presentation.

Vinyl graphics should be white, black, or gold/silver leaf vinyl unless approved by landlord. Window signage should be a designed signage element that complements the design of the overall storefront presentation.

No electronic open or closed signs permitted. Tenants are encouraged to have a custom open and closed sign. Open and closed signs may be affixed to the glazing with suction cups or masked VHB tape.

Landlord, at any time, may provide comments /feedback not covered in this list to a Tenant's signage design and / or fabrication that in Landlord's opinion is not in keeping with the architectural character or overall quality of the development. Window signage determined to be garish in nature or any other items which in the sole opinion of the Landlord are detrimental to the image of the shopping center will not be permitted.

Section 3. Window Graphics / Window Graphics Specifications

Window graphics refers to any signage applied to glazed storefront or doors.

Window graphics may be dimensional if applied to outer surface of glass. Interior/second surface of glass to be treated as appropriate to cover back of sign and/or attachment so that sign has finished appearance from storefront interior.

Applied vinyl graphics to be installed on second (inner) surface of glass.

All vinyl graphics to be UV resistant.

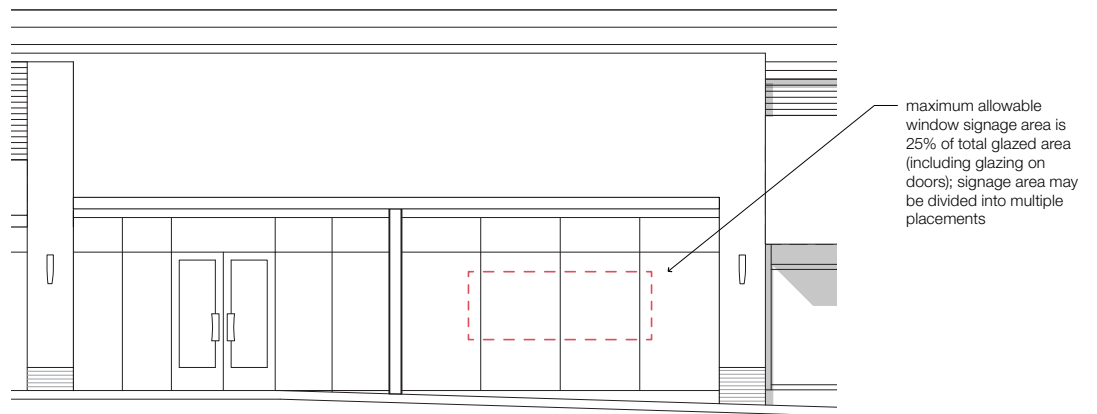

1 Window Signage Diagram
SCALE: NTS

Section 3. Window Graphics / Window Graphics Specifications

Window Graphics Examples



Section 3. Window Graphics / Operational Signs

Operational Signs Placed on Windows

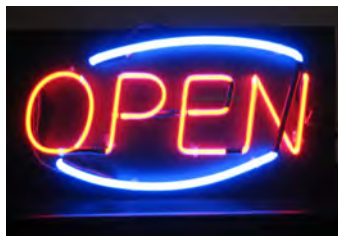

NOT allowed

Section 4. Storefront Enhancement

Temporary Window Displays

Window displays are a critical component of the overall business presentation and encourage spur of the moment purchases.

Window shopping is an important element for retailers as close to 60% of sales are spur of the moment, and by engaging good design practices we can help capture this activity and create great, lasting impressions for our shopper.

Temporary window displays give merchandise a backdrop and create a visually attractive focal point opportunity to advertise overall tone and feel of store through printed material and merchandise display. Simple backdrops help highlight displays. This section refers to temporary or non permanent elements that are either simply merchandise display or merchandise accompanied by posters or other graphics with information on them.

Posters must be integrated with display items and remain current & relate to product / merchandising being displayed. Displays that are left in place for longer than six months may be asked to be replaced by Landlord

There can be one advertising element for every three window sections. A minimum size of 24"x24" or one total window size.

Advertising graphics shall not be adhered to glass, tape is not permitted. Posters shall be suspended centered between mullions.

Display Illumination

Integral lighting is recommended for all window displays. All displays to remain illuminated until 12AM.

Warm down lights or spotlights highlight displays and create an inviting business front.

No neon or internally lit elements are allowed unless approved by Landlord.

When using spotlights or track lighting to wall wash or highlight display, lighting must be seamlessly integrated into display, and no wiring or electrical will be visible from exterior

Base specification for display lighting is as follows:
Juno Track Lighting T317B-WH Flat Back Cylinder - Line Voltage 120W BR40/150W PAR38, Black or White color baffle.



NOT allowed

Section 4. Storefront Enhancement

Outdoor Spaces

Bryan, College Station, Texas offers many days a year that outdoor dining is desirable, the local culture revels in spending time outside. Restaurants, as permitted by lease, are encouraged to create visually activated, interesting outdoor spaces. Patio areas should be considered to be extensions of the interior space and help complete the overall presentation of the restaurant.

Tenants seeking to alter an existing outdoor area to accommodate outdoor food and beverage shall follow the same development process as part of the overall design and submittal process identified in this guideline document.

The addition of new barricades, shading devices, or any architectural feature will be considered on a case by case basis by Landlord.

Outdoor patios shall be in compliance with all local, state, and federal laws, codes and ordinances.

See this section for allowable furnishing selections. Tenants may offer their own furnishing selections for Landlord approval.

Patios shall include, but are not limited to the following:

- a. Adequate serving, storage, waiting and delivery infrastructure as necessary to accommodate the stated capacity. Waste, storage or recycling containers cannot degregate the outward visual appearance of the patio from parking lots, entry drives or sidewalks of the property;
- b. Sufficient lighting to create an interesting, safe, comfortable environment;
- c. Not encroach or burden common sidewalks, parking areas, or adjacent tenant spaces;
- d. Clean, well-maintained furnishings;
- e. Planters and potted plants in tenant controlled areas kept in good presentation;
- f. Fire and water features kept in good, safe working order. features that are broken beyond repair shall be removed or replaced;
- g. Heating and misting devices kept in good, safe working order;

Note: The Landlord may modify this list at any time to include any material specific to a tenant's patio design that in the Landlord's opinion is not in keeping with the architectural character or overall quality of the development.



Section 4. Storefront Enhancement

Awnings

Awnings and other exterior building-mounted fabric curtains and drapes should be simple to compliment storefront composition. Awnings and curtains shall be simple and have no side panels and have very minimal structure.

Awnings and other exterior building-mounted fabric curtains and drapes should be balanced and scaled appropriately with architectural elements and be specific for sun and rain protection.

Colors shall be in black, gray or tan. Alternate colors are allowed only with written permission from The Landlord. Pattern and decorative elements are strictly prohibited. Specific fabric color to be submitted to the Landlord for review / approval.

Fabrication shop drawings shall reviewed and approved by the Landlord prior to installation.

Structural frames should be structurally sound and have open ends.

Tenant shall maintain / clean or replace awnings as needed due to fading, dirt, etc.

Tearing or structural damage must be replaced immediately.

Tenant is responsible for associated maintenance costs unless otherwise noted.



Section 4. Storefront Enhancement

Outdoor Display

Tips and Recommendations

Sidewalk displays are a great way to attract attention to a business and helps create a rich outdoor retail experience.

Consider how your merchandise or services can be displayed in an attractive, unique manner,

Businesses may have outdoor display of merchandise, lifestyle objects, pots/planters and/or furniture. The outdoor displays must support a product or service.

Overall displays shall be neat and organized and support a single theme. Multiple display themes will look cluttered and detract from the business front. Displays shall be well maintained and stored securely after business hours.

All display furniture and planters/pots shall be approved by the landlord. Displays may only be placed immediately in front of a business front and, shall not cause any pedestrian impediments.

Prohibited items include: blow up features, flags or vinyl printed signs; these shall not be placed on the exterior of the business either on the facade or part of sidewalk display.

Landlord, may at any time, ask a business to alter or remove a display.



Section 4. Storefront Enhancement

A-Frame Stands

A frame stands or more commonly called sandwich boards are permitted if they meet the Landlord required specifications

Stands are to be purchased and maintained by the Business. Approved stands are shown below. A business may propose a stand of equal quality. (Shall be subject to landlord approval.)

Do not clutter display with too much content; work with chalkboard artist when possible. Keep sign simple and clean.

White or black boards are allowed; use white or black markers only and markers only, refresh messaging and graphics as needed.

Use white vinyl graphics for messaging that will remain permanent.

Do not use colored chalk unless approved by landlord.

Do not display dirty or outdated boards.



NOT allowed

Section 4. Storefront Enhancement

A-Frame Stands

Note: all prices subject to change



Hooks & Lattice
Blank A-Frame Folding
Sidewalk Sign
\$150

URL: www.hooksandlattice.com
ID: S12-NP
Dimensions: W21" H41"
Message Area: W20 3/16" H35 3/16"



Webstaurant
American Metalcraft Securit
A-Frame Sign Board
\$168

URL: <http://www.webstaurant-store.com/>
ID: 124SBSM135
Dimensions: W30" H54"



Vagabond Vintage
Recycled Wood Framed
Chalkboard
XL \$96 | M \$52

URL: <http://www.mothology.com/>
ID: WC-CHALK-XL
Dimensions: W18" H40"
ID: WC-CHALK-M
Dimensions: W16" H21"

Section 4. Storefront Enhancement

Outdoor Furniture**Outdoor Furnishings**

Exterior tenant spaces can be enhanced with outdoor furnishings. Independent of property furnishings, tenant supplied items such as benches, pots, tables and chairs help further define their presentation and provide more amenities to customers.

Uses of outdoor furnishings

Use planters to define space.

Use benches as places to gather.

Use outdoor seating that compliments storefront.

Use outdoor seating to activate under-utilized outdoor space.

Guidelines

Outdoor Furniture and planters may be used as permitted in lease.

Tenants may refer to the pre-approved landlord options provided for outdoor furniture specifications. Proposed items not on the pre-approved list must be of like quality and be replaceable or repairable.

Quantities of furnishings and layout placement outside of lease area shall require landlord approval.

Items on the pre-approval list are to be purchased, ordered and maintained by business unless specified in lease; pricing is provided as reference only and may change. Confirm pricing and availability with supplier at time of purchase.

Section 4. Storefront Enhancement / Outdoor Furniture

Outdoor Furnishings

Note: all prices subject to change



Source Contract
Palm Square Table
\$324-\$395

URL: <http://www.wayfair.com>
ID: SOUR1071
Dimensions: Various Sizes



Florida Seating
Teak Restaurant Patio Table
\$209

URL: <http://www.centralrestaurant.com>
ID: 407-023
Dimensions: H29" D32"



Euro Style
Sheldon Dining Table
\$279

URL: www.contemporaryfurniturewarehouse.com
ID: 04109
Dimensions: D27.5" W27.5" H29"



Source Contract
Valencia Round Table
\$233-\$322

URL: www.wayfair.com
ID: SOUR1064
Dimensions: Various Sizes



Zuo Modern
Capital Square Dining Table
\$278

URL: <http://www.totallyfurniture.com/>
ID: zuo-703212
Dimensions: W31.5" L31.5" H28"



Emu Americas
Forte Table
\$312

URL: www.hotelrestaurantsupply.com
ID: EMU-860
Dimensions: D24" W24" H29.5"

Section 4. Storefront Enhancement / Outdoor Furniture

Outdoor Furnishings

Note: all prices subject to change



American Hospitality
Brighton Arm Chair
\$98

URL: www.americanhospitality-furniture.com
ID: A-7005BLK
Dimensions: W22" H34" D21"



Source Contract
Amelia Dining Side Chair
\$150

URL: www.sourceoutdoor.net
ID: SC-2406-162
Dimensions: W20" H35" D23"



BFM Seating
Monterey Stackable Side Chair
Java Wicker
\$109

URL: <http://bfmseating.com>
ID: PH500CJV-BFMS



American Hospitality
Gulf Coast Chair
\$89

URL: www.americanhospitality-furniture.com
ID: A-7005TK



Fermob Bistro Chair
Folding Chair
\$108

URL: www.fermobusa.com
ID: 0101



Emu Americas
Stacking Chair
\$325

URL: www.emuamericas.com
ID: 267
Dimensions: H33" W20.5" D21"



SKY BLUE INDOOR-OUTDOOR STEEL PATIO ARM CHAIR WITH SQUARE BACK

\$35

URL: www.flashfurniture.com
ID: CO-2-SKY-GG
color options available



BFM Seating
Maze Stacking Armchair
\$82

URL: <http://bfmseating.com>
ID: DV360BL

Section 4. Storefront Enhancement / Outdoor Furniture

Outdoor Furnishings

Note: all prices subject to change



Ore
Channel Bench
\$1700

URL: www.orecontainers.com
Alt. URL: www.yardcouture.com
Dimensions: L72" W18" H18"



Ore Containers
Plank Bench (Cedar Block Leg)
\$1400

URL: www.orecontainers.com
Alt. URL: www.yardcouture.com
Dimensions: L60" W18" H18"



Landscape Forms
Wellspring Bench
\$610-\$1280

URL: www.landscapeforms.com
Dimensions: Various Sizes



Zuo Modern Contemporary
Colby Bench
\$578

URL: <http://www.totallyfurniture.com/>
ID: zuo-98320
Dimensions: W67" L14" H18"



Teak Warehouse
Blok Reclaimed Teak Bench
\$845

URL: www.teakwarehouse.com
Dimensions: W14" L90" H19"



Equiparc
Dimanche Bench with Backrest
\$2,072

URL: www.equiparc.com
ID: EP 1930
Dimensions: H33.5" D23.25" L71"
Wood: Jatoba, Ipe, White Oak, Select Douglas Fir and Hardwood



Terrain
Protected Teak Garden Bench
\$798

URL: www.shopterrain.com
ID: 30293104
Dimensions: H34.5" W58.5" D25.5"

Section 4. Storefront Enhancement / Outdoor Furniture

Outdoor Display

Note: all prices subject to change



Candy Concepts
3 Basket Oval Merchandiser
\$276

URL: www.candyconceptsinc.com
ID: 83004-25-643
Dimensions: W24 1/2" H60"
D20"



World Market
Wood and Metal Aiden
End Table
\$170

URL: www.worldmarket.com
ID: 437977 odlhMCvA
Dimensions: 20.1" Sq. x H25.2"



Candy Concepts
3Tier Double Sided
Vegetable Bin
\$250

URL: www.candyconceptsinc.com
ID: 82915-VB-6
Dimensions: H64" W21.25"
D29.5"



World Market
Antique White Adirondack
Side Table
\$50

URL: www.worldmarket.com
ID: 502826
Dimensions: 18" Sq. x H17"



Candy Concepts
basket rack display
\$145

URL: www.candyconceptsinc.com
ID: 82913-20055
Dimensions: W26.75" D18.5"
H55"



Signature Design by Ashley
Marxim End Table
\$124

URL: www.wayfair.com
ID: GNT8575
Dimensions: H19.75" W12" D12"

Section 4. Storefront Enhancement / Outdoor Furniture

Outdoor Umbrellas

Note: all prices subject to change



Portofino

Octagon

Price varies per specification

URL: <http://www.portofinoumbrellas.com>

Alt. URL: <https://www.tropitone.com>

Dimensions: D 7.5', 8.5', 9.5', 10.5'

All solid color options with
Landlord approval.
Patterns, stripes or with
signage prohibited. Single color only.



Tucci

Octagon, Square, Rectangle

Price varies per specification

URL: <http://www.tucci.com>

Alt. URL: <https://www.restorationhardware.com>

Dimensions: varies

All solid color options with
Landlord approval.
Patterns, stripes or with
signage prohibited. Single color only.



CorLiving

Price varies per specification

URL: <http://www.corliving.com>

Alt. URL: <https://www.Wayfair.com>

Dimensions: L,W 6'

All solid color options with
Landlord approval.
Patterns, stripes or with
signage prohibited. Single color only.

Section 4. Storefront Enhancement / Outdoor Furniture

Outdoor Planters and Pots

Note: all prices subject to change



Hayneedle
Coral Coast Dark Brown Planter
\$87

URL: www.hayneedle.com
ID: HN-XCD020
Dimensions: L16" D16" H27.5"



Accent Decor
Newport Rectangular
Concrete Planters
\$410

URL: www.houzz.com
Dimensions: W27.5" D10" H12"



Serralunga
Torre Planter
\$106-387

URL: www.allmodern.com
URL: LUN1007
Dimensions: Various Sizes



Atelier Vierkant
MHR

URL: www.ateliervierkant.com



Pennoyer
Modern Square Planter
\$600-\$2000

URL: www.pennoyernewman.com
Dimensions: Various Sizes



Lechuza
Cubico Color 40 Planter,
White Matte
\$50-\$140

URL: www.lechuza.us
ID: 13150
Dimensions: Various Sizes